



DEVELOPMENT AND CHARACTERIZATION OF A CATALYTIC MEMBRANE FOR VOLATILE ORGANIC COMPOUND COMBUSTION

M. N. Kajama^{1,*} and Y. Yildirim²

¹DEPARTMENT OF MECHANICAL ENGINEERING, UNIVERSITY OF MAIDUGURI, MAIDUGURI, BORNO STATE, NIGERIA

²DEPARTMENT OF ENVIRONMENTAL ENGINEERING, BULENT ECEVIT UNIVERSITY, ZONGULDAK, TURKEY

*E-mail addresses:*¹mohd_nasiru@yahoo.com; ²yilmaz.yildirim@beun.edu.tr

ABSTRACT

Platinum-alumina (Pt/ γ -Al₂O₃) catalytic membranes were obtained using the reservoir technique for the combustion of volatile organic compounds (VOCs). The membranes were characterized by scanning electron microscopy and energy dispersive X-ray analysis (SEM-EDXA) observation, Brunauer-Emmett-Teller (BET) measurement and gas permeation. Propane (C₃H₈) and n-butane (C₄H₁₀) combustion was obtained. Maximum VOC conversion for propane and n-butane of 93 and 48 (%) was achieved on 3.52wt% Pt catalyst at a temperature of 427 and 259 (°C) and flow rates of between 185-222 and 295-379 (ml/min) without any changes in conversion. The combustion results of C₃H₈ and C₄H₁₀ corroborate with literature on Pt/ γ -Al₂O₃ catalysts. The conversion was achieved using flow-through catalytic membrane reactor operating in the Knudsen flow regime.

Keywords: catalytic membrane, volatile organic compounds, organic combustion, platinum-alumina

1. INTRODUCTION

Volatile organic compounds (VOCs) are released into the atmosphere from chemical plants, aircraft manufacturers, food processing facilities, textile manufacturers, painting facilities, wood stoves, etc. All organic compounds that boil at 50-260 (°C), exclusive of pesticides but including dichloromethane, are VOCs [1]. VOCs are grouped as aliphatic hydrocarbons such as propane and n-butane, aromatic hydrocarbons include toluene and benzene, ketones for example acetone, among others [2]. Ground-level ozone build-up is largely due to the increased availability of ozone forming precursor VOCs and oxides of nitrogen (NO_x). Furthermore, in the presence of VOCs and nitric oxide (NO), the degradation reactions of VOCs could lead to the formation of intermediate radicals such as peroxy radicals (RO₂). Peroxy radicals react with atmospheric NO, converting NO to nitrogen dioxide (NO₂) which then photolyzes to form tropospheric ozone [3]. Additionally, some symptoms related to adverse health impact are quite common and are associated with short term exposure to VOCs. These symptoms include; headaches, allergic skin reaction, visual disorders, dizziness, coughing, eye and respiratory tract irritation and fatigue. Likewise, brain damage, damage to the nervous, kidney, reproductive and immune systems are associated with long term exposure to VOCs [4].

Emissions of VOCs could be a result of natural sources, although, most VOC emissions result from anthropogenic sources. The degree of VOCs released yearly into the atmosphere from man-made sources alone constitute to about 235 million tonnes [4]. From an environmental point of view, curtailing these vapour emissions could lead to a vital landmark in the oil and process industries.

Consequently, imposing stricter regulations can actually abate the release of VOCs into the environment [5]. In recent years, the emissions of VOCs have been rigorously regulated across the globe. For example, "in the air quality standards developed by the United States Environmental Protection Agency (USEPA) the maximum 3-hour concentration of 0.24 parts per million (ppm) hydrocarbon content should not be exceeded for a period of more than a year" [6,7]. The Gothenburg protocol also states that by 2020 the European Union (EU) countries agree to curb VOC emission levels by nearly 50% compared to the year 2000 [5].

There are different techniques/methods applied to control VOC emissions. These techniques are categorised as either destruction or recovery (Figure 1). Pollutants can be destroyed by either incineration/oxidation or by biodegradation. The most extensively applied VOC destruction

techniques/methods are thermal and catalytic oxidation. These are applied whereby VOCs are mixed with oxygen (O_2) at specified temperatures and the products are carbon dioxide (CO_2) and water (H_2O). In general, the chemical reaction is written as:

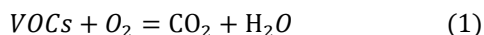

Membrane reactors have been receiving considerable attention for over half a century and a number of papers have been published on the subject of membrane science, catalysis and chemical engineering [8-12]. Membranes are used as an active material in chemical conversion in accelerating the reaction rate, selectivity and yield. Membrane reactors have been largely demonstrated on the laboratory scale for hydrogenation, oxidation reactions, dehydrogenation, and decomposition [8].

The concept of membrane reactors for chemical conversion has yet to be extensively commissioned for industrial application. However, some small industrial installations are active. The disadvantage of membrane reactors in order to be commercially industrialized are the membrane themselves, their support and issues including stability, cost and performance which require enhancement [8]. The combination of membranes and reactors is being proposed in recent years, and is classified into three i.e.; extractor, distributor and contactor. 'Extractor' this concept is used to selectively remove the product(s) from the reaction mixture. 'Distributor' is used to control the addition of reactants to the reaction mixture and lastly 'Contactor' is used to

intensify the contact between reactants and the catalyst [8].

The forced flow-through contactor for VOC oxidation (which was also employed in this paper) is a distributor type concept mode which is largely employed by many researchers [13-21]. VOC destruction to carbon dioxide and water using Pt/ γ - Al_2O_3 catalysts has been claimed by several authors [22-26]. Additionally, Pt catalysts are superior in comparison to (gold) Au-containing systems and Co_3O_4 - CeO_2 mixed oxides [26, 27]. Pina *et al.*, [28] have suggested the concept of employing the Knudsen-diffusion catalytic membrane reactor for the combustion of VOCs. They have highlighted that a flow-through configuration of a membrane reactor operating in the Knudsen diffusion regime provides an intimate contact between VOC and O_2 molecules as well as the active sites. In another development, Saracco and Specchia, [29] have succeeded in using catalytic filters through tailored techniques. These catalytic filters were tested for their performance towards catalytic combustion of selected VOCs. Their experimental data corroborate with those predicted by an isothermal model based on a pseudo-homogeneous approach and solved numerically by the finite-difference method. In addition, Benard *et al.*, [30] also studied the chemical reaction of the catalytic oxidation of VOCs for conventional and a flow-through catalytic membrane reactor comparison. Their findings exhibited that the catalytic membrane reactor was superior to the conventional one in terms of efficiency.

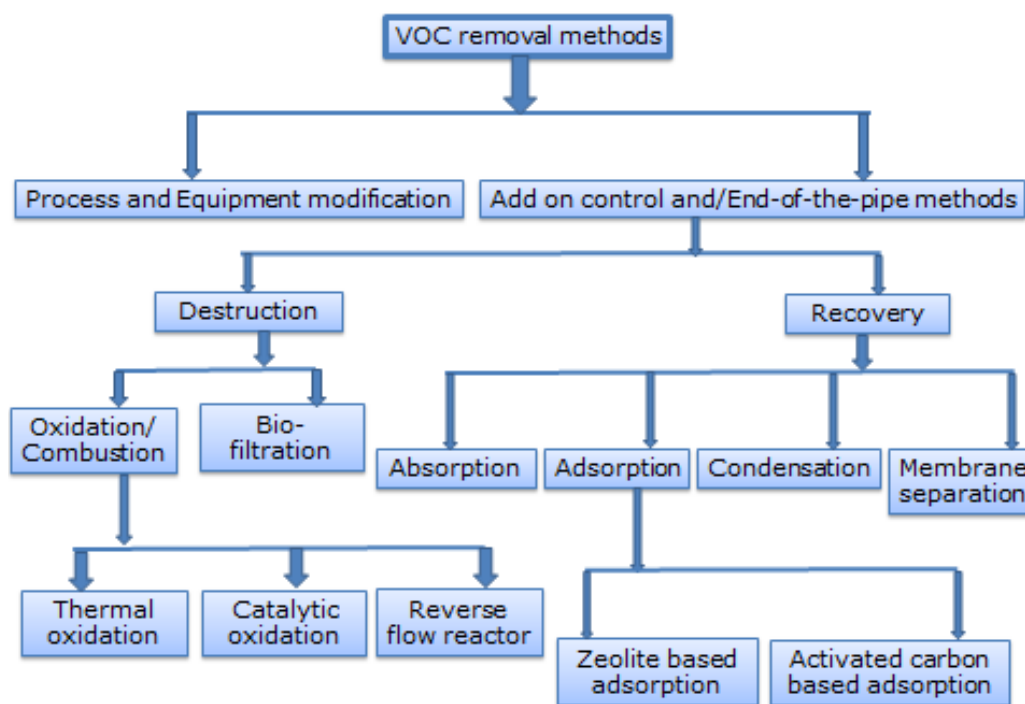

Figure 1: VOC controls methods [6].

They have suggested that, flow-through membrane reactor could lead to decreased light-off and total VOC combustion in addition to a lower Pt loading.

In this study, the performance of catalytic membrane reactor was studied with the aim to investigate the possibility of improving VOC conversion using a commercially available alumina (Al_2O_3) support impregnated with Pt catalyst. The $\text{Pt}/\gamma\text{-Al}_2\text{O}_3$ membrane was subsequently incorporated into a flow-through membrane shell and tube configuration. The effects of the main operating variables such as the feed molar flow rates, reaction temperatures, and partial pressures were examined.

2. EXPERIMENTATION

A schematic diagram of the experimental rig is illustrated in Fig. 2. It consists of feed delivery (where pure gas was fed), a membrane reactor and analytical systems. The reactor used was tubular shell and tube configuration. The shell was made from stainless steel material and has 28mm internal diameter (I.D), 36mm outer diameter (O.D), 395mm long and 5mm thick. The two ends of the reactor system were removable for membrane replacement purposes. Graphite rings (one at each end) were used as sealing for the alumina tube ends. The reactants were introduced into the reactor feed side using mass flow controllers. The reaction experiments occurred at atmospheric pressure within the stainless steel reactor. The product (permeate) was analysed by CO_2 analyser (CT2100-Emissions Sensor). The water formed in the reaction was removed from the effluent in a moisture trap at room temperature. Several factors were considered in selecting the membrane for this experiment. Al_2O_3 support was chosen because of its lower maintenance cost, although its permselectivity is slightly low. $\text{Pt}/\gamma\text{-Al}_2\text{O}_3$ was used due to its high catalytic activity for VOC destruction [22, 27, 31] leading to low operating temperature.

2.1 Membrane Support

The Al_2O_3 (symmetric membrane) tube supplied by Ceramiques Techniques et Industrielles (CTI SA) France, composed of 77% Al_2O_3 and 23% TiO_2 possesses an I.D and O.D of 7 and 10 mm respectively. The Al_2O_3 consisted of a porous length of 348mm and a porosity of 0.45. This Al_2O_3 membrane was selected owing to the fact that it has good resistance to oxidation as well as chemical and mechanical stability at high temperature.

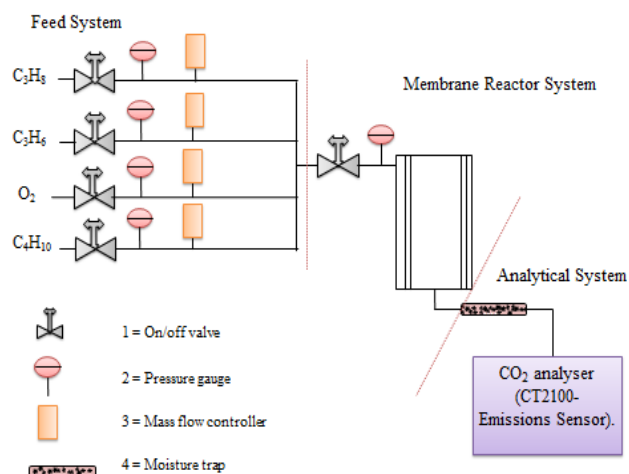

Figure 2: Schematic diagram of the feed, membrane reactor and analytical systems.

2.2 Catalytic Membrane Preparation

The $\text{Pt}/\gamma\text{-Al}_2\text{O}_3$ membrane was prepared via dip-coating method. Chloroplatinic acid solution (H_2PtCl_6) was used as a platinum precursor. The Al_2O_3 support was first dried at 65°C . It was dipped for 2 hours in deionised water prior to Pt introduction.

The deposition method employed was based on the evaporation-crystallization steps. This system named as "reservoir" technique which was proposed by (Uzio, *et al.*, 2003; Iojoiu *et al.*, 2003; Kajama *et al.*, 2016) [32-36]. The Al_2O_3 tube was dipped in a 10g/l H_2PtCl_6 precursor solution for 10 hours after it was dipped for 2 hours in deionised water. The $\text{Pt}/\gamma\text{-Al}_2\text{O}_3$ membrane was then dried at room temperature for 24 hours to favour evaporation from the inner side and deposition on the top layer. Metallic platinum was obtained after thermal treatment of the $\text{Pt}/\gamma\text{-Al}_2\text{O}_3$ membrane under flowing hydrogen at 400°C for at least 2hrs followed by nitrogen flow for 1hr at 400°C [35].

2.3 Membrane Characterization

SEM and EDXA of the membrane were examined before and after Pt impregnation. The samples used for SEM and EDXA were obtained by crushing the membrane into small pieces. SEM and EDXA results indicated the presence of Pt. The membrane was found to be defect-free.

3. RESULTS AND DISCUSSION

3.1 Catalyst Characterization

Platinum metal catalyst was employed due to its relatively high activity in VOC destruction over other noble metals [22]. BET surface area and the average pore size measurement of the Al_2O_3 support and $\text{Pt}/\gamma\text{-}$

Al₂O₃ membrane samples were obtained. Table 1 presents the data of specific surface area, average pore diameter and pore volume of the Al₂O₃ support and Pt/γ-Al₂O₃ membrane. The results clearly indicate an increase in BET surface area between the Al₂O₃ support and Pt/γ-Al₂O₃ membrane. This increase may be attributed to the formation of nano-dispersed platinum particles. In addition, a decrease in the average pore diameter was obtained which is possibly due to pore blockage caused by the metal platinum particles. However, no alteration was observed with respect to the pore volume on both the Al₂O₃ support and Pt/γ-Al₂O₃ membrane samples [36].

Table 1: BET surface area, average pore diameter and pore volume measurements of the Pt-alumina membrane [36].

Catalyst	BET surface area (m ² /g)	Average pore diameter (nm)	Pore volume (cm ³ /g)
Support	0.364	4.171	0.005
Pt-alumina	0.426	3.7	0.005

Nitrogen (N₂) adsorption/desorption isotherm of the calcined Pt dispersed membrane is shown (Figure 3a). The isotherm is a Type IV isotherm. Figure 3b depicts the pore diameter measured by the Barrett-Joyner-Halenda (BJH) method of the calcined Pt membrane. The result reveals a fairly narrow pore size distribution. The average pore diameter was 3.7nm, and the majority of pore diameters are smaller than 50nm. In addition, the majority of pores are larger than can be successfully measured using gas sorption.

3.2 SEM & EDXA of Pt/γ-Al₂O₃ Membrane

SEM and EDXA of the Pt/γ-Al₂O₃ membrane were examined after Pt impregnation. Figure 4 (a, b, c and d) depict the SEM images of the Pt membranes inner, outer, cross-section and edge respectively. Pt depositions can be clearly observed on the SEM images shown on Figures 4 (a and b). The SEM image of the edge of the Pt/γ-Al₂O₃ membrane is also shown on Figure 4 (d) with a thickness of between 10 - 12 microns.

Moreover, the compositional results are shown (Table 2). After Pt impregnation, it can be seen (Table 2) that a 3.52wt% Pt is obtained. Pt is the active catalyst for the proposed reaction in order to facilitate the reaction of VOC and O₂ to generate CO₂ and H₂O.

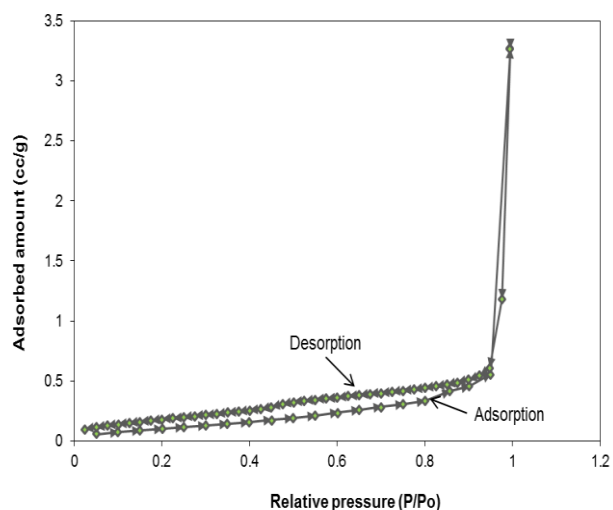

(a)

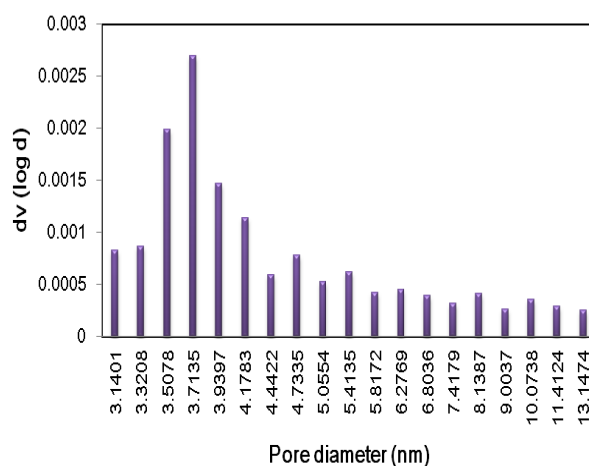

(b)

Figure 3: (a) N₂ adsorption/desorption isotherm of Pt membrane (b) Pore-size distribution of Pt membrane measured by N₂ adsorption.

Table 2: Outer surface EDXA of Pt membrane [37].

Element	Weight (%)	Atomic (%)
CaCO ₃ (C K)	14.41	19.64
SiO ₂ (O K)	50.68	51.88
Al ₂ O ₃ (Al K)	38.52	23.38
SiO ₂ (Si K)	0.28	0.16
KCl (Cl)	3.28	1.51
Wollastonite (Ca K)	0.32	0.13
Titanium (Ti K)	7.94	2.72
Zirconium (Zr L)	1.61	0.29
Platinum (Pt M)	3.52	0.30
Total	120.56	100.02

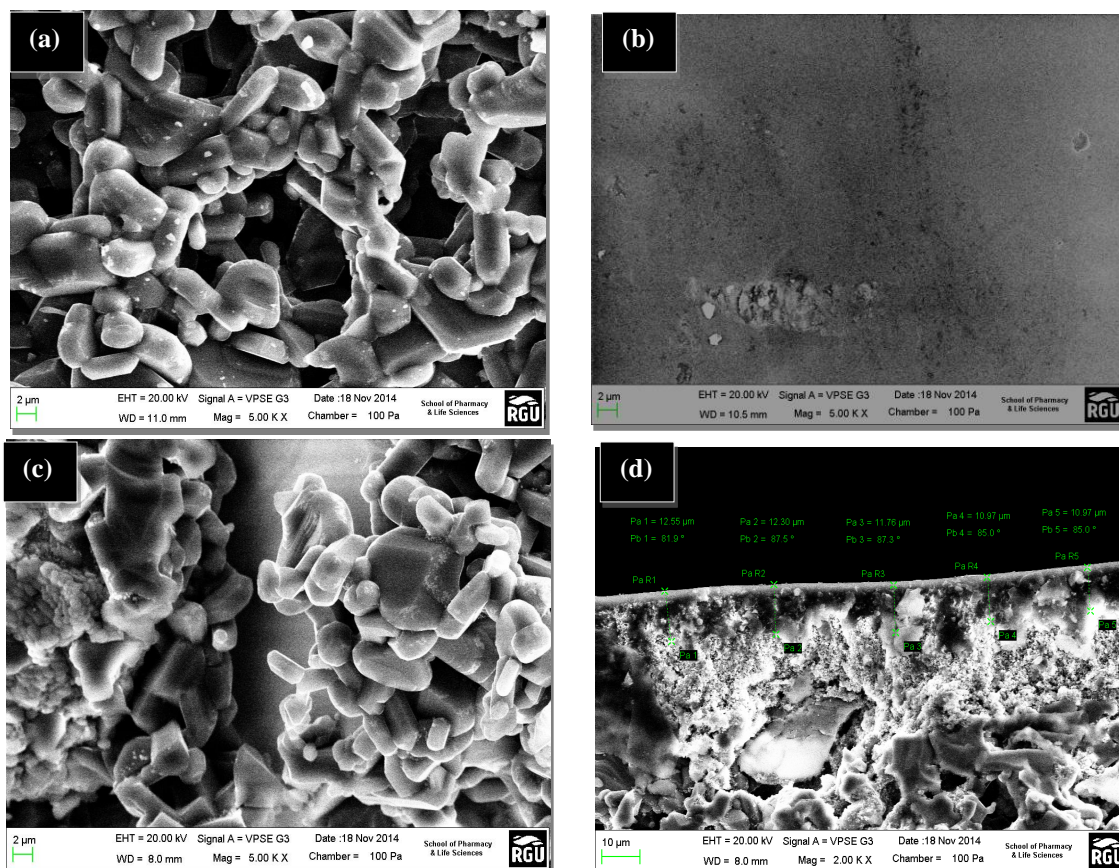

Figure 4: (a) SEM image of the Pt membrane inner surface (b) SEM image of the Pt membrane outer surface (c) SEM image of the Pt membrane cross-sectional area (d) SEM image of the Pt membrane edge surface.

3.3 Gas Permeation

Permeation experiments were carried out at room temperature using propylene single gas in order to quantify Knudsen flow contribution. Figure 5 depicts the permeate flux of the virgin and Pt/Al₂O₃ membranes. Eqn. (2) was used to relate the permeation flux and average pressure [28].

$$F = \beta P_{av} + K \quad (2)$$

where β and K are given by;

$$\beta = 0.125 \frac{\varepsilon r^2}{L\tau\mu RT}, K = 1.06 \frac{\varepsilon r}{L\tau\sqrt{MRT}} \quad (3)$$

where, F is the permeation flux per unit of time and area, ε is the porosity of the membrane (%), r is the mean pore radius (m), $P_{av} = (P_1 + P_2)/2$ is the average pressure (Pa), μ is the viscosity (Pa-s) and L is the thickness of the membrane (m), τ is the tortuosity, M is the molecular weight of the diffusing gas (g/mol), R gas constant (8.314 J.K⁻¹.mol⁻¹) and T the permeation temperature (K). β and K can be regarded as viscous and Knudsen contributions to the permeation flux [28]. It can be seen (Figure 5) that the Al₂O₃ (virgin membrane) was influenced mainly by viscous flow contribution. On the other hand, after 3.52wt% Pt impregnation, a lower slope was obtained for the Pt/ γ -

Al₂O₃ membrane with a decrease of permeates flux (Figure 5) from (8.8 to 8.2 x10⁻⁶) which indicates Knudsen diffusion contribution. The obtained result is in agreement with the literature [28]. Pina, *et al.*, [28] obtained similar results using untreated gamma-alumina (α -Al₂O₃) membrane. After depositing 4.9wt% of γ -Al₂O₃ at 1 bar, they achieved an almost horizontal line indicating predominantly Knudsen diffusion contribution.

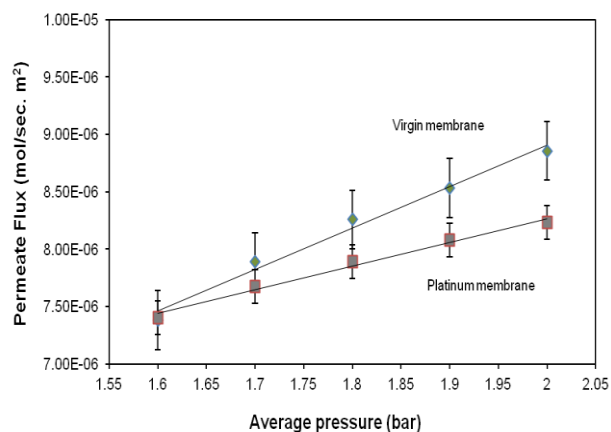

Figure 5: Permeation flux across alumina support (virgin membrane) and platinum membrane against average pressure at room temperature.

3.4 VOC Conversion

A CO₂ analyser (Cascade's CT2100 sensors) was connected from the catalytic membrane reactor permeate side. As the reactants (VOC and O₂) were fed into the feed side of the catalytic membrane reactor, combustion/conversion occurred at different flow rates, pressures and reaction temperatures, where the products (CO₂ and H₂O) permeated through the permeate side of the membrane reactor, passing through the moisture trap (where the H₂O is been absorbed) through a digital flowmeter to the CO₂ analyser in order to record the percentage concentration of the product CO₂. The CO₂ analyser was calibrated before the experiment. The conversion of VOCs was calculated using eqn. (4) [38, 39].

$$X_{VOC}(\%) = \frac{VOC_i - VOC_o}{VOC_i} \times 100 \quad (4)$$

where VOC_i is the flow rate of VOC at the feed recorded from the flow meter, and VOC_o is the permeate flow rate of VOC at the permeate recorded from the flow meter respectively. The catalytic membrane was exposed to several activity runs. The same membrane was then cooled down prior to each experiment.

Figure 6 depicts propane conversion against reaction temperature across 3.52wt% Pt-Al₂O₃ membrane at flow rates between 185 to 222ml/min without any changes in conversion. The general behaviour of the Pt/ γ -Al₂O₃ based catalysts result is in good agreement with that reported in the literature. Propane conversion of 93% was achieved at a temperature of 427°C, this result corroborates the literature [29]. This could be as a result of strong interaction of the Pt catalyst which facilitated the chemical reaction at lower temperature compared to thermal oxidation. It should be noted that this conversion was attained at only a fraction of the catalyst loading compared to the literature [29].

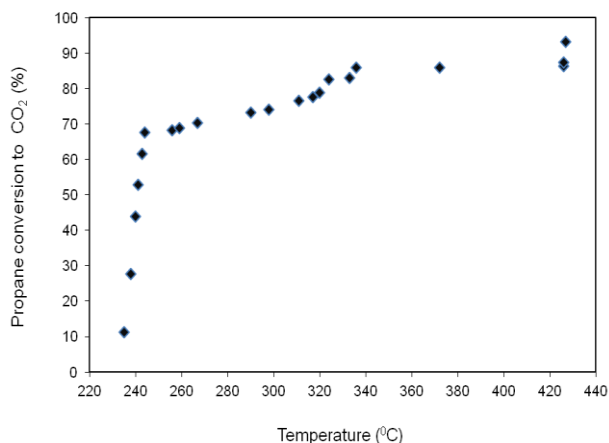

Figure 6: Propane conversion against reaction temperature.

Figure 7 depicts the conversion of n-butane against reaction temperature across 3.52wt% Pt-Al₂O₃ membrane at flow rates between 295 to 379ml/min without any changes in conversion. It can be seen (Figure 7) that the highest n-butane conversion of 48% was achieved at a temperature of 259°C on Pt/ γ -Al₂O₃ membrane. This demonstrates that the performance of a catalytic membrane reactor is influenced by the operating parameter such as temperature.

In order to compare the conversions between the aliphatic hydrocarbons (propane and n-butane), a 48% propane conversion was achieved at only 242°C whereas in the case of n-butane a 48% was achieved at a temperature of 259°C. In other words, propane recorded lower reaction temperature than n-butane at 48%. The high activity behaviour could be possibly due to the ability of Pt catalyst over propane compared to n-butane.

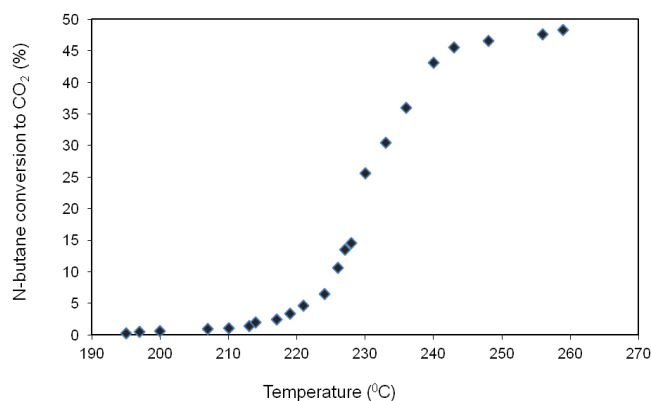

Figure 7. N-butane conversion against reaction temperature.

The above result is an indicative where the temperature at which the combustion takes place depends on the nature of the VOC present in the waste gas stream as well as the Pt/ γ -Al₂O₃ membrane.

4. CONCLUSIONS

The experimental VOC conversion using a flow-through catalytic membrane reactor operating in the Knudsen diffusion regime has been demonstrated using the simple but effective "reservoir technique". The stainless steel membrane reactor designed was operated at high-temperature without any deterioration. VOC conversion was significantly higher. The conversion of VOC using Pt/ γ -Al₂O₃ membrane was obtained at moderate temperatures. Consequently, the maximum conversion obtained by the Pt-Al₂O₃ membrane was comparable with literature. The membrane employed maintained a prolong activity and stability without any catalytic degradation.

5. ACKNOWLEDGEMENTS

The authors gratefully acknowledge Petroleum Technology Development Fund (PTDF) Nigeria for funding this research; Centre for Process Integration and Membrane Technology, (CPIMT) School of Engineering, The Robert Gordon University, Aberdeen, United Kingdom for providing the membrane reactor, and School of Pharmacy & Life Sciences RGU Aberdeen for the SEM results.

7. REFERENCES

- [1] Aguado S, Coronas J, Santamaría J. Use of zeolite membrane reactors for the combustion of VOCs present in air at low concentrations. *Chemical Engineering Research and Design*; 83 (3):295-301, 2005.
- [2] Pina M, Irusta S, Menéndez M, Santamaria J, Hughes R, Boag N. Combustion of volatile organic compounds over platinum-based catalytic membranes. *Ind Eng Chem Res*; 36 (11):4557-4566 1997.
- [3] Atkinson, R. Atmospheric chemistry of VOCs and NO_x. *Atmospheric Environment*, (34):2063-2101, 2000.
- [4] Rusu A. O., Dumitriu E. Destruction of volatile organic compounds by catalytic oxidation. *Environmental Engineering and Management Journal*; 2(4):273-302, 2003.
- [5] Liotta L. F. Catalytic oxidation of volatile organic compounds on supported noble metals. *Applied Catalysis B: Environmental*; 100 (3-4):403-412, 2010.
- [6] Khan FI, Ghoshal AK. Removal of volatile organic compounds from polluted air. *J Loss Prev Process Ind*; 13 (6):527-545, 2000.
- [7] Tamaddoni M, Sotudeh-Gharebagh R, Nario S, Hajihosseinzadeh M, Mostoufi N. Experimental study of the VOC emitted from crude oil tankers. *Process Saf Environ Prot*; 92 (6):929-937, 2014.
- [8] Julbe A, Farrusseng D, Guizard C. Porous ceramic membranes for catalytic reactors—overview and new ideas. *J Membr Sci*; 181 (1):3-20, 2001.
- [9] Coronas J, Santamaria J. Catalytic reactors based on porous ceramic membranes. *Catalysis Today*; 51 (3):377-389, 1999.
- [10] Hwang S. Inorganic membranes and membrane reactors. *Korean Journal of Chemical Engineering*; 18 (6):775-787, 2001.
- [11] Lu G, da Costa J. D., Duke M, Giessler S, Socolow R, Williams R, *et al.* Inorganic membranes for hydrogen production and purification: a critical review and perspective. *J Colloid Interface Sci*; 314 (2):589-603, 2007.
- [12] Uemiya S. Brief review of steam reforming using a metal membrane reactor. *Topics in Catalysis*; 29 (1-2):79-84, 2004.
- [13] Saracco G, Specchia V. Catalytic ceramic filters for flue gas cleaning. 2. Catalytic performance and modeling thereof. *Ind Eng Chem Res*; 34 (4):1480-1487, 1995.
- [14] Irusta S, Pina M, Menendez M, Santamaria J. Development and application of perovskite-based catalytic membrane reactors. *Catalysis letters*; 54 (1-2):69-78 1998.
- [15] Dittmeyer R, Höllein V, Daub K. Membrane reactors for hydrogenation and dehydrogenation processes based on supported palladium. *Journal of Molecular Catalysis A: Chemical*; 173(1):135-184, 2001.
- [16] Lange C, Storck S, Tesche B, Maier W. Selective hydrogenation reactions with a microporous membrane catalyst, prepared by sol-gel dip coating. *Journal of Catalysis*; 175 (2):280-293, 1998.
- [17] Yamada M, Fugii K, Haru H, Itabashi K. Preparation and catalytic properties of special alumina membrane formed by anodic oxidation of aluminum. The Light Metal Educational Foundation, Inc., Report of the Research Group for Functionalizing of Aluminum and Its Surface Films: 175-182, 1988.
- [18] Splinter A, Stürmann J, Bartels O, Benecke W. Micro membrane reactor: a flow-through membrane for gas pre-combustion. *Sensors Actuators B: Chem*; 83(1):169-174 2002.
- [19] Zalamea S, Pina M, Villellas A, Menéndez M, Santamaría J. Combustion of volatile organic compounds over mixed-regime catalytic membranes. *Reaction Kinetics and Catalysis Letters*; 67 (1):13-19, 1999.
- [20] Maira A. J, Lau WN, Lee C. Y, Yue PL, Chan C. K, Yeung K. L. Performance of a membrane-catalyst for photocatalytic oxidation of volatile organic compounds. *Chemical engineering science*; 58(3):959-962 2003.
- [21] Tsuru T, Kan-no T, Yoshioka T, Asaeda M. A photocatalytic membrane reactor for gas-phase reactions using porous titanium oxide membranes. *Catalysis Today*; 82 (1):41-48, 2003.
- [22] Benard S, Ousmane M, Retailleau L, Boreave A, Vernoux P, Giroir-Fendler A. Catalytic removal of propene and toluene in air over noble metal

- catalyst. *Canadian Journal of Civil Engineering*; 36(12):1935-1945, 2009.
- [23] Radic N, Grbic B, Terlecki-Baricevic A. Kinetics of deep oxidation of n-hexane and toluene over Pt/Al₂O₃ catalysts: Platinum crystallite size effect. *Applied Catalysis B: Environmental*; 50 (3):153-159 2004.
- [24] Kim D. H, Kung M. C, Kozlova A, Yuan S, Kung H. H. Synergism between Pt/Al₂O₃ and Au/TiO₂ in the low temperature oxidation of propene. *Catalysis letters*; 98 (1):11-15, 2004.
- [25] Tahir SF, Koh C. A. Catalytic destruction of volatile organic compound emissions by platinum based catalyst. *Chemosphere*; 38 (9): 2109-2116, 1999.
- [26] Gluhoi A. C, Bogdanchikova N, Nieuwenhuys BE. Total oxidation of propene and propane over gold-copper oxide on alumina catalysts: Comparison with Pt/Al₂O₃. *Catalysis today*; 113 (3):178-181, 2006.
- [27] Liotta L, Ousmane M, Di Carlo G, Pantaleo G, Deganello G, Boreave A, et al. Catalytic removal of toluene over Co₃O₄-CeO₂ mixed oxide catalysts: comparison with Pt/Al₂O₃. *Catalysis Letters*; 127(3-4):270-276, 2009.
- [28] Pina M, Menéndez M, Santamaria J. The Knudsen-diffusion catalytic membrane reactor: an efficient contactor for the combustion of volatile organic compounds. *Applied Catalysis B: Environmental*; 11 (1):L19-L27, 1996.
- [29] Saracco G, Specchia V. Catalytic filters for the abatement of volatile organic compounds. *Chemical Engineering Science*; 55(5):897-908, 2000.
- [30] Bénard S, Giroir-Fendler A, Vernoux P, Guillaume N, Fiaty K. Comparing monolithic and membrane reactors in catalytic oxidation of propene and toluene in excess of oxygen. *Catalysis Today*; 156(3):301-305, 2010.
- [31] Paulis M, Peyrard H, Montes M. Influence of chlorine on the activity and stability of Pt/Al₂O₃ catalysts in the complete oxidation of toluene. *Journal of Catalysis*; 199 (1):30-40, 2001.
- [32] Uzio D, Miachon S, Dalmon J. Controlled Pt deposition in membrane mesoporous top layers. *Catalysis today*; 82 (1):67-74, 2003.
- [33] Iojoiu E, Walmsley J, Raeder H, Bredesen R, Miachon S, Dalmon J. Comparison of different support types for the preparation of nanostructured catalytic membranes. *Reviews on Advanced Materials Science*; 5(3):160-165, 2003.
- [34] Kajama M. N., Nwogu N. C, Gobina E. Preparation and characterization of inorganic membranes for hydrogen separation. *International Journal of Hydrogen Energy*; 41 (19):8221-8227, 2016.
- [35] Kajama M. N, Nwogu N. C., Gobina E. Catalytic membrane reactor for VOC destruction 1. *Transactions on Engineering Technologies*; 163-177, 2016.
- [36] Kajama M. N., Shehu H, Okon E, Orakwe I, Gobina E. VOC oxidation in excess of oxygen using flow-through catalytic membrane reactor. *International Journal of Hydrogen Energy*; 41(37):16529-16534, 2016.
- [37] Kajama M. N, Nwogu N. C, Okon E. O, Shehu H, Orakwe I, Gobina E. Hydrogen Separation Using Pt-Alumina Impregnated Membrane. *Energy and Power Engineering*; 7:412-417, 2015.
- [38] Delimaris D, Ioannides T. VOC oxidation over MnO_x-CeO₂ catalysts prepared by a combustion method. *Applied Catalysis B: Environmental*; 84(1):303-312, 2008.
- [39] Delagrance S, Pinard L, Tatibouet J. M. Combination of a non-thermal plasma and a catalyst for toluene removal from air: Manganese based oxide catalysts. *Applied Catalysis B: Environmental*; 68(3):92-98, 2006.