



OPTIMIZATION OF DESIGN FORMULATIONS FOR REINFORCED CONCRETE SLABS

O. S. Abejide*

DEPARTMENT OF CIVIL ENGINEERING, AHMADU BELLO UNIVERSITY, ZARIA. NIGERIA

E-mail address: abejideos@yahoo.com

Abstract

The predictions for flexural requirements in singly reinforced concrete slabs and sections have been assessed using the minimum weight approach and mathematical programming. Results indicate that although the predictions in the codes are safe; they are quite conservative, expensive and encourage abuse. The value of under-estimation ranges from 17% to 27% in the codes. A more precise stress block may be necessary in order to reduce if not eliminate under-estimation. It is suggested therefore, that fully probabilistic design formulations be employed for the determination of flexural requirements of reinforced concrete slabs or sections in order to eliminate or at least minimize abuse(s) that can subsequently result into the reduction of the structural integrity or outright failure of such members.

Keywords: reinforced concrete slabs, flexure, mathematical programming, design formulations, codes.

1. Introduction

An evaluation of the flexural resistance of singly reinforced concrete solid slabs with the optimum weight required for structural safety and economy and as stated in design codes [1, 2, 3, 4, 5] is presented.

It is a well-known fact by many design engineers that the choice of the size of a reinforced concrete section is controlled by many factors, which includes: (i) intuition and experience of the design engineer; (ii) relative cost of steel to concrete; (iii) choice of limiting steel ratio; (iv) member size imposed by the architect usually for uniformity or aesthetics and (v) serviceability conditions.

When member size restrictions are not imposed, the design engineer is always faced with the problems of choosing the smallest, cost effective and most efficient concrete section and reinforcement. This is the optimum section. A rational approach to the selection of an optimum slab section that is satisfactory at both the ultimate and serviceability limit states includes the determination of the effective depth and height of slab, area of reinforcing steel, depth of concrete in compression; and sometimes design experience. But it must be noted that experience has shown that there are variability in the resulting designs by engineers on the same project and structural element. This indicates

that there is a region of safety and also that there must be some probabilistic approach to the design of these slabs in order to achieve the best option for the particular situation.

However, some bases for fully probabilistic formulations oriented towards the production of optimum structural designs have been given [6, 7, 8, 9, 10, 11]. The factors suggested include using adequate procedures for analysis and designs, tolerances in geometry, ductility and strength catalogue of available bar sizes. Also, they emphasized that optimum design decisions are to be made in the light of results from quality control in productions both at the factory and on the site. Thus, optimum designs can be approached from a global application, but starting initially from the optimization of individual units or criterion. The Lagrange's method [12, 13, 14, 15] is used herein, to evaluate the ultimate limit-state of bending of a singly reinforced concrete slab. The equations presented herein have been developed using the mathematical programming approach. Mathematical programming methods are intended to solve a problem by numerical search algorithm. The optimization procedures can be readily applied in different design problems.

In this report, the effective depth of the concrete slab section is based on the simplified stress profile as recommended in the codes [1, 2, 3, 4,

* Corresponding author, Tel: +2348035908260

5]. Figures 1 and 2 show a typical stress diagram for a singly reinforced concrete section as presented in BS8110. It has been argued [5] that for normal purposes the idealization of the stress-strain relationships in concrete is so similar as to be indistinguishable. Hence, the simplified relationship is also adopted herein for Eurocodes [4, 5] predictions or formulations. For

ease of formulation, the cost function is based on a linear sum of the cost of concrete and the required reinforcement for safety. But it must be noted that the cost function is related to the moment capacity and the effective depth of a reinforced concrete slab section.

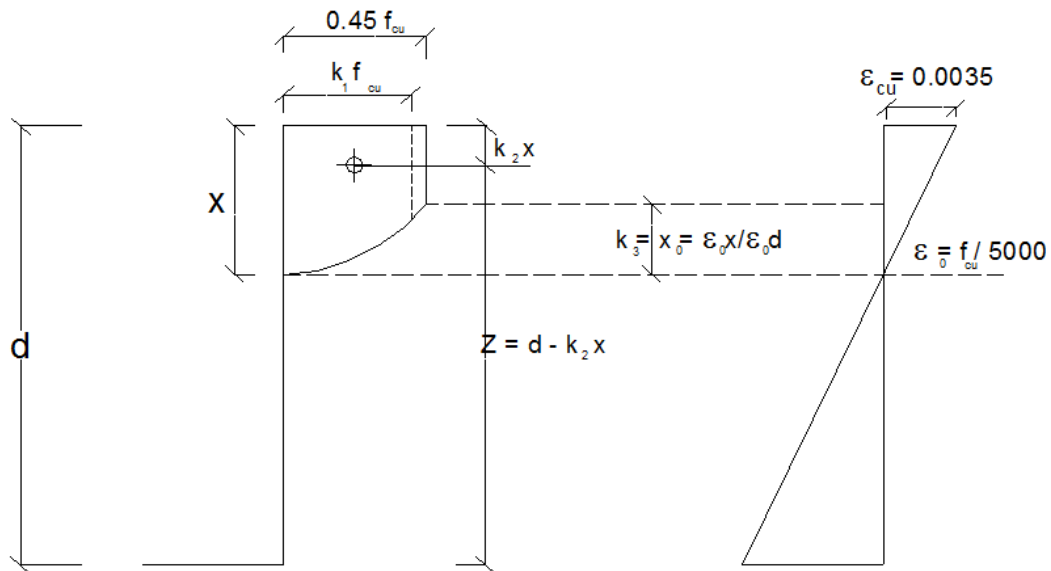

(a) Parabolic Rectangular stress (b) strain distribution

Figure 1: Design stress block for ultimate limit state [BS8110, 1985; 1997]

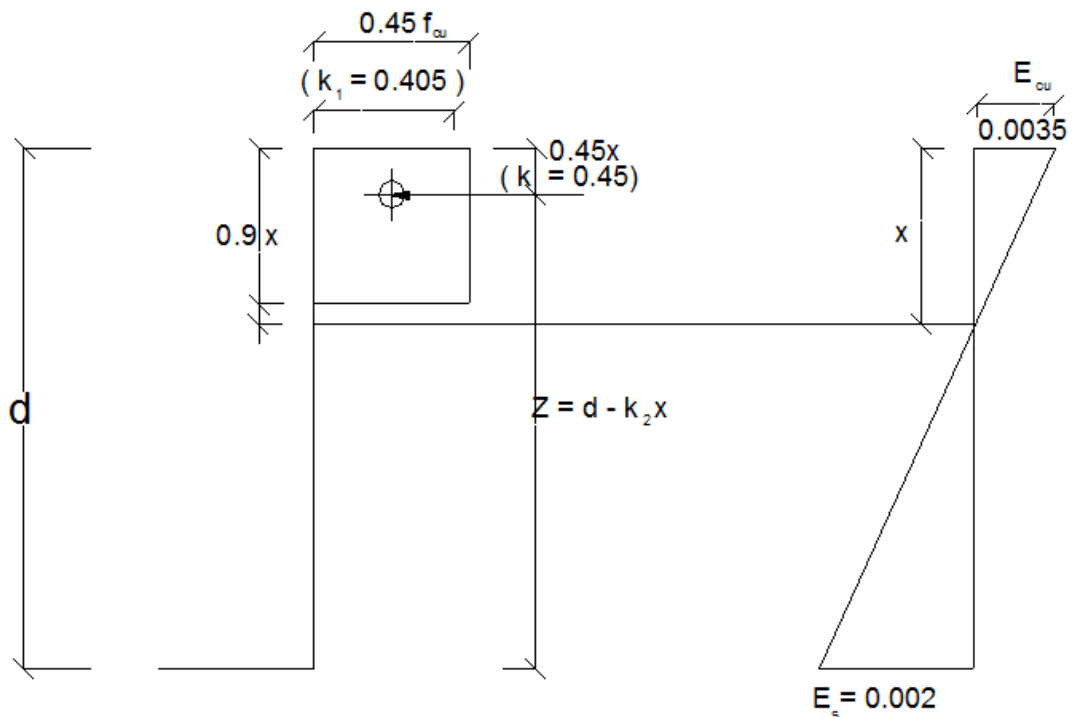

(a) Rectangular stress (b) strain distribution

Figure 2: Simplified stress block for ultimate limit state [BS 8110, 1985; 1997]

Also, the resulting expression is optimized using the Lagrange's multipliers' method leading to a set of design variables.

At the ultimate limit state, it is important that sections subject to bending be ductile, with failure occurring by the gradual yielding of tension steel bars rather than the catastrophic sudden failure of the concrete in compression [1, 2, 3, 4, 5, 16, 17, 18, 19, 20, 21, 22]. For equilibrium of the slab concrete section, the tensile force, F_{st} , in the reinforcement, must be balanced by the compressive force, C_{cc} , in the concrete as shown in Figures 1 and 2.

2. Materials and Methods

2.1 Establishment of design functions

The ultimate moment of resistance, M_u , of the slab is given as:

$$M_u = 0.45 f_{cu} b x \left(d - \frac{x}{2} \right) \quad (1)$$

In (1), b is the breadth of section; x is the depth to neutral axis from compression face; d is the effective depth and f_{cu} is the concrete strength.

Equation (1) can also be written as;

$$M_u = k b d^2 \quad \text{or} \quad d = C \sqrt{\frac{M_u}{b}} \quad (2)$$

where k , is a parameter and $C = \sqrt{1/k}$.

The ratio of reinforcement area to the concrete section, ρ , may be given as:

$$A_s = \rho b d \quad (3)$$

where, A_s is the area of steel reinforcement.

A cost function will involve the weight of the reinforced concrete slab member. Thus, the total cost will be equal to the cost of the flexural reinforcement and concrete. Now, if C_s and C_c represent the unit costs of steel and concrete per unit volume respectively, then the cost of the slab of unit length is given as:

$$COST = C_s V_s + C_c V_c \quad (4)$$

where V_s and V_c are the volumes of steel and concrete of a unit length of slab respectively and are derived as:

$$V_s = 1.A_s = \rho b d \quad (5)$$

$$V_c = 1.(d - d_s)b \quad (6)$$

If d_s is the distance of tensile steel centroid to the tensile face, then, the reinforcement ratio,

$$\rho = A_s / (bd).$$

When a rectangular section is to be designed, the loads and hence the ultimate bending moment, M_u , height of slab, h , and material properties, f_{cu}

and f_y are generally known. Thus, the effective depth, d , and area of tension steel are to be determined. In this formulation, the quantities, C and ρ in equations (2) and (3) are used as design variables of the optimum design problem instead of d and A_s because M_u and b (breadth of slab section) are eliminated favourably in the constraints and objective function. Substituting equation (5) and (6) in equation (4), we obtain;

$$COST = C_s \rho b C \sqrt{\frac{M_u}{b}} + C_c (1 + t) b C \sqrt{\frac{M_u}{b}} \quad (7)$$

where, $t = d_s/d$. Let the ratio of the unit cost of steel to that of concrete be given as q . Therefore,

$$q = \frac{C_s}{C_c} \quad (8)$$

Thus, equation (7) becomes;

$$COST = \{ \rho q + (1 + t) \} C.C_c \sqrt{b M_u} \quad (9)$$

The parameter, $C_c \sqrt{b M_u}$, can be taken as a constant for a given slab, since the parameters, C_c , b and M_u are constant for the slab under consideration. Therefore, minimize the COST function:

$$Y = \{ (1 + t) + \rho q \} C \quad (10)$$

where Y is the COST function.

The ultimate moment of resistance of a reinforced concrete slab section may also be written in terms of the tensile steel as equations (11a) or (11b) for the codes [1, 2, 3, 4, 5] respectively:

$$M_u = 0.87 f_y A_s \left(d - \frac{x}{2} \right) \quad (11a)$$

(CP110,1972; BS8110,1985,EC2,2008)

$$M_u = 0.95 f_y A_s \left(d - \frac{x}{2} \right) \quad (11b)$$

(EC2,1995; BS8110,1997)

Now, equating forces from the stress blocks (see Figures 1 and 2) gives,

$$0.45 f_{cu} b x = 0.87 f_y A_s \quad (12a)$$

(CP110,1972; BS8110,1985,EC2,2008)

$$0.45 f_{cu} b x = 0.95 f_y A_s \quad (12b)$$

(EC2,1995; BS8110,1997)

or

$$x = \frac{0.87 f_y A_s}{0.45 b f_{cu}} \quad (\text{CP110; BS8110,1985,EC2,2008}) \quad (13)$$

$$\text{or} \quad x = \frac{0.95 f_y A_s}{0.45 b f_{cu}} \quad (\text{EC2,1995; BS8110,1997})$$

Substituting M_u from equation (2) into equation (11) and x from equation (12) we obtain,

$$\frac{0.95f_y^2 \rho^2 C^2}{f_{cu}} - 0.87f_y \rho C^2 + 1 = 0 \quad (14a)$$

(CP110; BS8110,1985; EC2,2008)

$$\frac{0.95f_y^2 \rho^2 C^2}{f_{cu}} - 0.95f_y \rho C^2 + 1 = 0 \quad (14b)$$

(EC2,1995; BS8110,1997)

Now, let

$$\gamma_1 = \frac{0.95f_y^2}{f_{cu}} \quad (15)$$

and

$$\gamma_2 = 0.87f_y \quad (CP110; EC2,2008; BS8110, 1985) \quad (16)$$

$$\text{or } \gamma_2 = 0.95f_y \quad (EC2,95; BS8110, 1997)$$

Substituting γ_1 and γ_2 for the corresponding values in equation (12) gives:

$$\rho C^2 (\rho \gamma_1 - \gamma_2) + 1 = 0 \quad (17)$$

Therefore, the optimum design cost of a reinforced concrete singly reinforced solid slab or section in flexure is to minimize equation (10) subject to the following constraints;

$$\rho_1 \leq \rho \leq \rho_u \quad (18)$$

This means that the optimum reinforcement ratio for the section lies between the minimum reinforcement ratio, ρ_1 and the maximum reinforcement ratio, ρ_u , as per codes requirement for a reinforced concrete slab or singly reinforced concrete section.

2.2 Application of Lagrange's Multipliers Method

By noting equation (18), the constraint on the problem is equation (17). The application of the Lagrange's multipliers method will lead to the solution of equation (16) so as to yield a set of design variables. The required Lagrange function, ϕ , for the slab in flexure may be defined as:

$$\phi = (Q + \rho q)C - \lambda \{ \rho C^2 (\rho \gamma_1 - \gamma_2) + 1 \} \quad (19)$$

where,

$$Q = (1 + t) \quad (20)$$

Partial derivative of ϕ with respect to ρ and C gives;

$$\frac{\partial \phi}{\partial \rho} = C[q - \lambda C(2\gamma_1 \rho - \gamma_2)] = 0 \quad (21)$$

and

$$\frac{\partial \phi}{\partial C} = \left[\begin{array}{l} (Q + \rho q) \\ - \lambda (2\gamma_1 C \rho^2 - 2\gamma_2 \rho C) \end{array} \right] = 0 \quad (22)$$

Now, eliminating λ from equation (21), we have,

$$\lambda = \frac{q}{C(2\gamma_1 \rho - \gamma_2)} \quad (23)$$

Substituting (23) in (22), we get

$$Q + \rho q - \frac{q}{C(2\gamma_1 \rho - \gamma_2)} * \{2\rho C(\rho \gamma_1 - \gamma_2)\} = 0 \quad (24a)$$

Solving equation (24a), we have

$$(Q + \rho q)[2C\rho\gamma_1 - C\gamma_2] - 2q\rho^2 C\gamma_1 + 2q\rho C\gamma_2 = 0$$

$$2QC\rho\gamma_1 + 2qC\rho^2\gamma_1 - CQ\gamma_2 - Cq\rho\gamma_2 - 2qC\rho^2\gamma_1 + 2qC\rho\gamma_2 = 0$$

Therefore,

$$\rho = \frac{QC\gamma_2}{2QC\gamma_1 + qC\gamma_2}$$

Now, dividing through by $QC\gamma_2$ we get for CP110 (1972),BS8110 (1985) and EC2 (2008), while the quantity $2.18f_y$ changes to $2.0f_y$ for EC2 (1995) and BS8110 (1997).

$$\rho = \frac{1}{\frac{2\gamma_1}{\gamma_2} + \frac{q}{Q}} \quad (24b)$$

Substituting for γ_1 , γ_2 and Q from equations(15), (16) and (20) respectively, we obtain that,

$$\rho_{opt}^m = \frac{1}{\frac{2.18f_y}{f_{cu}} + \frac{q}{(1+t)}} \quad (25)$$

Also, substituting in the equation of constraint, that is, equation (17),

$$\rho_{opt}^m (C_{opt}^m)^2 (\rho_{opt}^m \gamma_1 - \gamma_2) + 1 = 0 \quad (26)$$

Hence,

$$C_{opt}^m = \frac{1}{\sqrt{\rho_{opt}^m (\gamma_2 - \gamma_1 \rho_{opt}^m)}} \quad (27)$$

Substituting the limiting values of reinforcement ratio, ρ , that is, minimum, ρ_1 and ultimate, ρ_u , in equation (27), we obtain, the ultimate value for the criterion, C_u , as:

$$C_u = \frac{1}{\sqrt{\rho_1 (\gamma_2 - \gamma_1 \rho_1)}} \quad (28)$$

and

$$C_1 = \frac{1}{\sqrt{\rho_u (\gamma_2 - \gamma_1 \rho_u)}} \quad (29)$$

Considering equation (18), the optimum steel ratio, ρ_{opt} , and optimum coefficient, C_{opt} , are as given in equations (30) and (31), with due

considerations of the provisions in relevant sections of the codes [1, 2, 3, 4, 5].

$$\begin{aligned}\rho_{opt} &= \rho_u ; \text{ if } \rho_u \geq \rho_{opt}^m \\ &= \rho_{opt}^m ; \text{ if } \rho_u \geq \rho_{opt}^m \geq \rho \\ &= \rho_1 ; \text{ if } \rho_1 \leq \rho_{opt}^m\end{aligned} \quad (30)$$

$$\begin{aligned}C_{opt} &= C_1 ; \text{ if } \rho_{opt} = \rho_u \\ C_{opt} &= C_{opt}^m ; \text{ if } \rho_{opt} = \rho_{opt}^m \\ C_{opt} &= C_u ; \text{ if } \rho_{opt} = \rho_1\end{aligned} \quad (31)$$

There are seven quantities involved in the design procedure, namely, f_{cu} , f_y , ρ_u , ρ_1 , M_u , t and q . But we know that ρ_1 and ρ_u are fixed as per code provisions. Thus, the required end result is to find the effective depth and steel area for each set of six variables. The large number of variables implies that there will be a large number of design results. For example, if each variable can assume two different values, then there will be about $2^6 = 64$ results; that is, two design engineers are likely to obtain 64 design results in one reinforced concrete slab design. The practical implication of this is the variability in the strength of reinforced concrete in existing and future structures. This is a dilemma in reinforced concrete designs.

However, from equations (30) and (2b) we can establish that

$$C_{opt}^m = \sqrt{\frac{1}{k_{opt}^m}} = \frac{1}{\sqrt{k_{opt}^m}} \quad (32)$$

Thus, from equation (26)

$$\frac{1}{\sqrt{k_{opt}^m}} = \frac{1}{\sqrt{\rho_{opt}^m (\gamma_2 - \gamma_1 \rho_{opt}^m)}} \quad (33)$$

Hence,

$$k_{opt}^m = \rho_{opt}^m (\gamma_2 - \gamma_1 \rho_{opt}^m) \quad (34)$$

The parameter describing k_{opt}^m is actually a function. Therefore, its optimal value will occur at a point of optimum gradient. Thus, we shall apply the partial derivatives of the function with respect to its principal variables. That is,

$$k_{opt}^m \equiv \rho_{opt}^m (q, t) \quad (35)$$

Re-writing equation (33), we have,

$$k_{opt}^m = \rho_{opt}^m \cdot \gamma_2 - \gamma_1 (\rho_{opt}^m)^2 \quad (36)$$

Differentiating equation (36) with respect to q and t we obtain,

$$\begin{aligned}\frac{\partial k_{opt}^m}{\partial q} &= \gamma_2 \cdot \frac{\partial \rho_{opt}^m}{\partial q} \\ &- 2\gamma_1 \cdot \rho_{opt}^m \cdot \frac{\partial \rho_{opt}^m}{\partial q} = 0\end{aligned} \quad (37a)$$

and

$$\begin{aligned}\frac{\partial k_{opt}^m}{\partial t} &= \gamma_2 \cdot \frac{\partial \rho_{opt}^m}{\partial t} \\ &- 2\gamma_1 \cdot \rho_{opt}^m \cdot \frac{\partial \rho_{opt}^m}{\partial t} = 0\end{aligned} \quad (37b)$$

From equation (25), we obtain for the British codes [1, 2] and Euro codes [5] as;

$$\frac{\partial \rho_{opt}^m}{\partial q} = \frac{d}{dq} \left[\frac{2.18 f_y}{f_{cu}} + \frac{q}{(1+t)} \right]^{-1} \quad (38)$$

$$\frac{\partial \rho_{opt}^m}{\partial q} = - \left[\frac{2.18 f_y}{f_{cu}} + \frac{q}{(1+t)} \right]^{-2} \cdot \frac{1}{(1+t)} \quad (39a)$$

Also,

$$\frac{\partial \rho_{opt}^m}{\partial t} = + \left[\frac{2.18 f_y}{f_{cu}} + \frac{q}{(1+t)} \right]^{-2} \cdot \frac{1}{(1+t)^2} \quad (39b)$$

Substituting equation (39) in equation (37) respectively we obtain,

$$\frac{\partial \rho_{opt}^m}{\partial q} \left[\gamma_2 - 2\gamma_1 \left[\frac{2.18 f_y}{f_{cu}} + \frac{q}{(1+t)} \right]^{-1} \right] = 0 \quad (40a)$$

$$\frac{\partial \rho_{opt}^m}{\partial t} \left[\gamma_2 - 2\gamma_1 \left[\frac{2.18 f_y}{f_{cu}} + \frac{q}{(1+t)} \right]^{-1} \right] = 0 \quad (40b)$$

Now, let

$$T = \left[\gamma_2 - 2\gamma_1 \left[\frac{2.18 f_y}{f_{cu}} + \frac{q}{(1+t)} \right]^{-1} \right] \quad (41)$$

Thus,

$$\frac{\partial \rho_{opt}^m}{\partial q} T = \frac{\partial \rho_{opt}^m}{\partial t} T = 0 \quad (42)$$

But, $T \neq 0$, therefore, from equation (39), we have,

$$-\frac{1}{(1+t)} - \frac{q}{(1+t)^2} \quad (43)$$

Solving equation (43) we obtain that

$$\frac{q}{(1+t)^2} = -\frac{1}{(1+t)} \quad (44)$$

$$\frac{q}{(1+t)} = -1 \quad (45)$$

This implies that

$$q = -(1+t) \quad (46)$$

Now, from equation (25), we can deduce that (EC2, 1995; BS8110, 1997).

$$\rho_{opt}^m = \frac{f_{cu}}{2.18f_y - f_{cu}} \quad (CP110; EC2, 2008; BS8110, 1985); \quad (47)$$

$$\rho_{opt}^m = \frac{f_{cu}}{2f_y - f_{cu}} \quad (EC2, 1995; BS8110, 1997)$$

Substituting equation (47) into equation (27) gives,

$$C_{opt}^m = \frac{1}{\left[\frac{f_{cu}}{2.18f_y - f_{cu}} \gamma_2 - \gamma_1 \left(\frac{f_{cu}}{2.18f_y - f_{cu}} \right)^2 \right]} \quad (48a)$$

(CP110; EC2, 2008; BS8110, 1985)

$$C_{opt}^m = \frac{1}{\left[\frac{f_{cu}}{2f_y - f_{cu}} \gamma_2 - \gamma_1 \left(\frac{f_{cu}}{2f_y - f_{cu}} \right)^2 \right]} \quad (48b)$$

(EC2, 1995; BS8110, 1997)

Also, substituting for γ_1 and γ_2 from equations (15) and (16) we get

$$C_{opt}^m = \frac{1}{\left[\frac{0.87f_{cu}f_y}{2.18f_y - f_{cu}} - 0.95f_y^2 \left(\frac{f_{cu}}{(2.18f_y - f_{cu})^2} \right) \right]} \quad (49a)$$

(CP110; EC2, 2008; BS8110, 1985)

$$C_{opt}^m = \frac{1}{\left[\frac{0.95f_{cu}f_y}{2f_y - f_{cu}} - 0.95f_y^2 \left(\frac{f_{cu}}{(2f_y - f_{cu})^2} \right) \right]} \quad (49b)$$

(EC2, 1995; BS8110, 1997)

Solving equation (49) we finally obtain for the British and Euro codes respectively as equations (50a) and (50b);

$$C_{opt}^m = \frac{(2.18f_y - f_{cu})}{\sqrt{[f_{cu}f_y(0.9466f_y - 0.87f_{cu})]}} \quad (50a)$$

(CP110; EC2, 2008; BS8110, 1985)

$$C_{opt}^m = \frac{(2f_y - f_{cu})}{\sqrt{[f_{cu}f_y(0.79f_y - 0.95f_{cu})]}} \quad (50b)$$

(EC2, 1995; BS8110, 1997)

3. Results of optimization technique

It is clear now, that the value of C_{opt}^m can be obtained at every choice of concrete and steel strength to be used in a reinforced concrete slab section. For example, when $f_{cu} = 20\text{N/mm}^2$ and $f_y = 250\text{N/mm}^2$, then, $C_{opt}^m = 0.501423287$, for the codes [1, 2, 5] prediction. Substituting C_{opt}^m in equation (32);

$$k_{opt}^m = \frac{1}{(C_{opt}^m)^2} = 3.977324272$$

Thus equation (2a) becomes:

$$M_u = 3.977324272 bd^2$$

The ultimate moment for a singly reinforced concrete section is given by the British codes [1, 2, 3] as:

$$M_u = 0.156bd^2 f_{cu} \quad (51a)$$

and by the Euro codes [4, 5] as:

$$M_u = 0.167bd^2 f_{cu} \quad (\leq C35/45) \quad (51b)$$

$$\text{or } M_u = 0.1376bd^2 f_{cu} \quad (> C35/45)$$

For example, in order to evaluate the resistance moment, it is proposed that equation (51a) be represented as;

$$M_u = 0.156\beta_o bd^2 f_{cu} \quad (52)$$

Note that β_o is the evaluation factor in equation (52). Therefore,

$$k_{opt}^m = 0.156 \beta_o f_{cu} \quad (52)$$

This means that (e.g. for the British codes [1, 2, 3],

$$0.156f_{cu} \beta_o = 3.977324272$$

But $f_{cu} = 20\text{N/mm}^2$, and we obtain,

$$\beta_o = \frac{3.977324272}{20 \times 0.156} = 1.274783421 \quad (53)$$

Therefore, for a singly reinforced concrete section made up of grade 20 concrete and mild steel reinforcement, the ultimate moment of resistance is under-estimated by about 27% in two British codes [1, 2]; and 25% in another British code [3]. Also, in the Eurocodes [4, 5] there is about 17% under-estimation for concrete grade less or equal to C35/45 and 29% under-estimation for concrete grade higher than C35/45. The amount of reduction in the value of under-estimation as indicated in the codes [3, 4, 5] simply shows the quantitative value of the quality control and cost associated with the codes respectively.

This same value of β_o can be obtained for the other singly reinforced concrete sections with various combinations of steel and concrete strengths as shown in Table 1. The value of the objective function in Table 1, which is less than unity in all the ranges of both concrete and steel strengths, simply indicates the effectiveness of the objective function and the optimization technique or procedure followed. The value of the parameter, t , in the objective function was taken as 0.06 and using nominal reinforcement in the codes as an example.

Table 1: Percentage Under-Estimation for Various Singly Reinforced Concrete Sections

S/No	Steel strength (f_y) N/mm ²	Concrete strength (f_{cu}) N/mm ²	$C^{m_{opt}}$	$K^{m_{opt}}$	β_o	% Under-estimation Rectangular stress block	Objective Function (Y)
CP110 (1972) and BS8110 (1985) Formulations							
1	250	20	0.5014232878	3.977324263	1.27478	27.48	0.5113
		25	0.4486886949	4.967178254	1.27364	27.36	0.4527
		30	0.4098254972	5.953907061	1.27220	27.22	0.4091
		40	0.3554487581	7.914910305	1.26842	26.84	0.3493
		50	0.3185685041	9.853586368	1.26328	26.33	0.3036
		60	0.2915793606	11.76214263	1.25664	25.66	0.2708
2	460	20	0.5011461432	3.981724572	1.27619	27.62	0.5204
		25	0.4482968641	4.975865105	1.27586	27.59	0.4630
		30	0.4093021708	5.969141910	1.27546	27.55	0.4205
		40	0.3546109847	7.952352654	1.27441	27.44	0.3603
		50	0.3173439714	9.929776994	1.27305	27.31	0.3187
		60	0.2898890984	11.89970604	1.27134	27.13	0.2877
BS8110 (1997) Formulations							
3	250	20	0.5080858791	3.873697916	1.24157	24.16	0.5161
		25	0.4558177094	4.813019390	1.23411	23.41	0.4577
		30	0.4174686562	5.737890448	1.22604	22.60	0.4727
		40	0.3642314879	7.537807185	1.20798	20.80	0.4229
		50	0.3286335345	9.259259259	1.18708	18.71	0.3096
		60	0.3030880997	10.88584711	1.16302	16.30	0.3720
4	460	20	0.5056115944	3.911703704	1.25375	25.38	0.6891
		25	0.4528541017	4.876221091	1.25031	25.03	0.3459
		30	0.4139928968	5.834642091	1.24672	24.67	0.2909
		40	0.3596375135	7.731611571	1.23904	23.90	0.2079
		50	0.3227606056	9.599286563	1.23068	23.07	0.1455
		60	0.2957328235	11.43407247	1.22159	22.16	0.0948
EC2 (1995) and EC2 (2008) Formulations							
5	250	20	0.5080858791	3.873697917	1.1668	16.68	0.4039
		25	0.4814371210	4.314404432	1.0396	13.96	0.3827
		30	0.4174686562	5.737890448	1.1522	15.22	0.3319
		40	0.3642314879	7.537807183	1.1352	13.52	0.2896
		50	0.3286335345	9.259259259	1.3458	34.58	0.2613
		60	0.3030880997	10.88584711	1.3185	31.85	0.2410
6	460	20	0.5056115944	3.911703704	1.17822	17.82	0.4716
		25	0.4528541017	4.876221092	1.17499	17.50	0.4224
		30	0.4139928968	5.834642091	1.17161	17.16	0.3862
		40	0.3596375135	7.731611570	1.16440	16.44	0.3355
		50	0.3435551164	8.472413793	1.23146	23.15	0.3205
		60	0.2957328235	11.43407247	1.38494	38.49	0.2759

4. Conclusion

The cost implications of the design criteria for singly reinforced concrete sections for slabs at the ultimate limit state of bending has been valued over the range of practical grades of concrete and steel reinforcement. It is clear from results obtained that the ultimate moment of resistance for a singly reinforced concrete slab in bending is under-valued irrespective of the stress block that may be used. There is an under-

estimation of practical value when the wholly rectangular stress block or any other stress block in design codes investigated is used. A more precise stress block may be necessary in order to reduce if not eliminate under-estimation.

However, the implications of this under-estimation are that economy is sacrificed for safety, while the design formulation may be said to be expensive. This is because more materials in terms of the concrete and steel have been used

to sustain a lower loading condition. This explains the basis behind encouragement or outright abuse of singly reinforced concrete slabs by construction practitioners. Other concrete elements need be evaluated the same way so as to ascertain the effectiveness of their formulation as prescribed in the design codes. It is suggested that the design criteria for reinforced concrete slabs and singly reinforced concrete sections in flexure be based on fully probabilistic formulations instead of the current pseudo-probabilistic formulations since this will ensure both safety and economy while eliminating or reducing abuse of these members.

References

- [1] CP110 (1972) *The structural use of concrete: Parts 1, 2 and 3*. Her Majesty's Stationery Office, British Standards Institution, London.
- [2] BS8110 (1985) *The structural use of concrete: Parts 1, 2 and 3*. Her Majesty's Stationery Office, British Standards Institution, London.
- [3] BS8110 (1997) *The structural use of concrete: Parts 1, 2 and 3*. Her Majesty's Stationery Office, British Standards Institution, London.
- [4] EC2 (2008) *Eurocode 2: Design of concrete structures*. BS EN 1992-1-2, European Committee for Standardization, CEN, Brussels.
- [5] EC2 (1995) Eurocode 2: Part 1.1: Design of concrete structures. *BS EN 1992-1-1. European Committee for Standardization*, CEN, Brussels.
- [6] Friel, L. L. [1974] Optimum singly reinforced sections. *Journal of the American Concrete Institute, ACI*, Vol. 71, No. 11. pp. 556 - 558.
- [7] Rosenblueth, E. [1976] Towards optimum design through building codes. *Journal of the Structural Division, ASCE*, Vol. 102, No. ST 3. March. pp. 591 - 607.
- [8] Ellingwood, B. [1978] *Reliability bases of load and resistance factor for reinforced concrete design*. National Bureau of Standards, Building Science Series 110, Washington D. C.
- [9] Ellingwood, B and Tallin, A [1984] Structural serviceability: floor vibrations. *Journal of Structural Division, ASCE*, Vol. 110, No.2. February. pp 437- 459.
- [10] Nowak, S. N and Collins, K. R. (2000) *Reliability of structures*. McGraw-Hill Companies Inc. New York. USA.
- [11] Ditlevsen, O and Madsen, H. O. (2005) *Structural reliability methods*. John Wiley and Sons. England.
- [12] Kirsch, U. [1981] *Optimum structural design*. McGraw - Hill Inc., New York. pp. 3 - 346.
- [13] Bazaraa, M. S; Sherali, H. D and Shetty, C. M. [1993] *Nonlinear programming: theory and algorithms*. Second edition. John Wiley and Sons Inc., New York.
- [14] Hamdy, A. T. [1997] *Operations research: An introduction*. Sixth edition. Prentice Hall Inc, New Jersey, USA. pp. 745 - 814.
- [15] Belegundu, A. D and Chandrupatla, T. R. [1999] *Optimization concepts and applications in engineering*. Prentice Hall, New Jersey, USA. pp 259 - 295.
- [16] Mosley, W. H and Bungney, J. H [1990] *Reinforced concrete design*. Fourth edition, Macmillan press limited, London. pp 193 - 195.
- [17] Mosley, W. H; Bungney, J. H and Hulse, R [2007] *Reinforced concrete design*. Sixth edition, Book Power limited, London. pp 58 - 98.
- [18] MacGinley, T.J and Choo, B.S [1997] *Reinforced concrete: design, theory and examples*. E & F.N Spon limited, London. pp 124 - 169.
- [19] Reynolds, C.E and Steedman, J.C [1997] *Reinforced concrete designers handbook*. 10th edition. E & F.N Spon, limited, London.
- [20] Nilson, A.H [1997] *Design of concrete structures*. 12th edition. McGraw-Hill companies, Incorporated. New York. pp 481 - 541.
- [21] Kong, F.K and Evans, R.H [1998] *Reinforced and prestressed concrete*. 3rd edition. E & F.N Spon, limited, London. pp 85 - 327.
- [22] Beeby, A.W and Narayan, R. S. [1995] *Designers handbook to Eurocode 2, Part 1.1: Design of concrete structures*. Thomas Telford, London.